

# SP210avi

Inline stencil printer



Technical Data	SP210avi
Max board size	450mm(x) by 400mm(y)
Min board size	25mm x 50mm
Maximum PCB weight	0.5kg (1lb)
Underside component clearance	15mm
Underside edge clearance	5mm
Minimum board edge clearance	3mm
Repeatability	20 microns (six sigma, cpk=1.6)
Max print area	450mm x 390mm
Max PCB thickness	Up to 5mm (0.2") including 1% warpage
Min PCB thickness	0.4mm
X/Y PCB Alignment	±5mm
Radial PCB Alignment	±3 degrees
Board support	Magnetic pins (Vacuum Option)
Stencil image	Front and centre dedicated
Stencil load/unload	Automatic using print head
Stencil frame size (max)	584mm x 584mm (Adjustable without adapters)
Stencil frame size (min)	300mm x 300mm
Under-screen cleaning	Vacuum fully programmable wet & dry
Squeegees	Metal or Polyurethane
Squeegee pressure	1-20kg
Squeegee control	Pneumatic using proportional valve
Print speed	5-250mm/sec
PCB separation speed	0.1-20mm/sec
Print modes	Print/print, flood/print, print/flood
Transfer height	SMEMA
Transfer height (Siemens)	Optional
Transport direction	Right-left, left-right, left-left, right-right
Transfer system	Single pair conveyors with round 3mm poly belt drive
Board clamping	Foils
Board stop	Mounted on camera and fully programmable
Throughput time	12 seconds (excluding process time)
Up/down line protocol	SMEMA (alternative interfaces available)
Conveyor orientation	Front rail dedicated
Conveyor width adjustment	Powered
Conveyors	3mm "O" Ring
Power consumption	13 amps
Power supply	110V - 240V
Air supply	0.2cfm at 5 Bar clean air supply 0.25cfm at 5 Bar clean air when vacuum tooling fitted
PCB support	Manual magnetic pins
Vision	Look down/look down
Camera field of view	10mm by 10mm
Camera system	Dual roving camera
User interface	Flat screen LCD monitor with keyboard and integral tracker ball
Number of fiducials	2
Fiducial size	0.5 - 5mm
Fiducial location	Anywhere on PCB
Stencil paste availability	Automatic measurement/alert
Weight	500kgs
Crated weight	630kgs
Dimension	1008mm (W) x 1275mm (D) x 2081mm (H)

All details are subject to change without prior notice.

### Options

- Automatic paste dispense - Max 1kg cartridge/Min 0.5kg cartridge
- Enclosed print cartridge - Paste puck
- 2D paste inspection
- 2D+ paste inspection with Gerber import tool and bridge detection
- Statistical Process Control (SPC)
- Laser guided tooling
- Flexi tooling
- Vacunest™

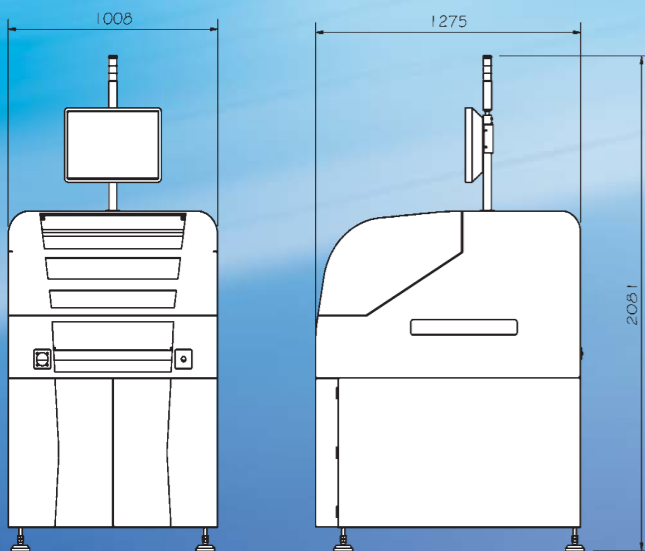

# SP210avi

Inline stencil printer

The core objective of Speedprint has always been to provide its customers with the most effective solution to their application through simplicity, innovation and quality of design.

This approach has led to the SP210avi, where all the critical elements of the process are provided as standard. The SP210avi combines the highest specification of design and components giving a very cost effective solution, therefore providing a high level of investment security.

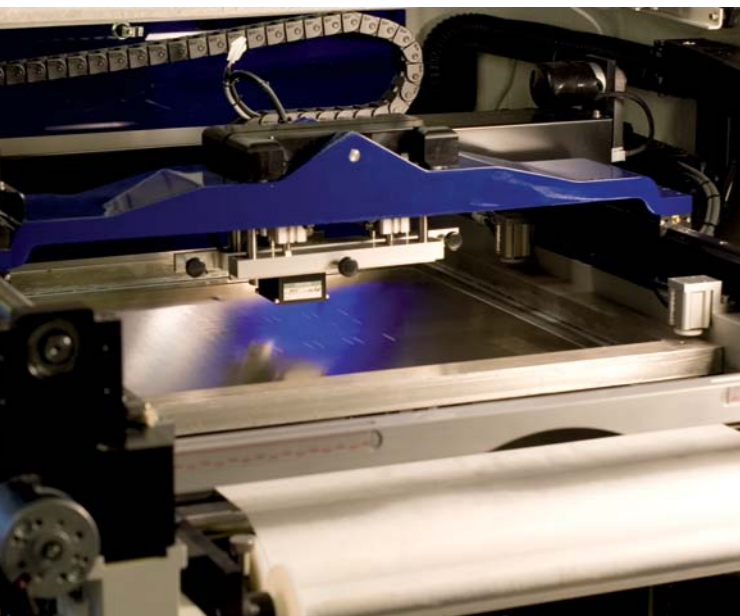

Developed as a flexible fine pitch Printer the SP210avi is ideal in any medium – high throughput environment, with all the functions necessary to provide years of uninterrupted high performance. The capability of the machine is based upon a platform which utilises the highest specification of components, combined with the latest innovations in Axis/Vision alignment.

The vision system utilises a unique twin roving camera 'Look Down, Look Down' method of automatic vision alignment. This ensures highly accurate and repeatable print performance. It is able to align the PCB with the stencil using fiducial marks and/or PCB/Stencil features.



As a standard feature the vision system, developed by Speedprint, facilitates a unique 'paste on stencil' inspection feature. This enables the user to determine that there is adequate paste on the stencil before running the print cycle.

The SP210avi incorporates 3Dc, an advanced user interface capable of running on Windows XP PRO or Vista™. In addition to the simple and intuitive nature of the interface, it also provides comprehensive self diagnostic capabilities, such as production logging and automatic fault report generation which enables 'on the fly' troubleshooting.

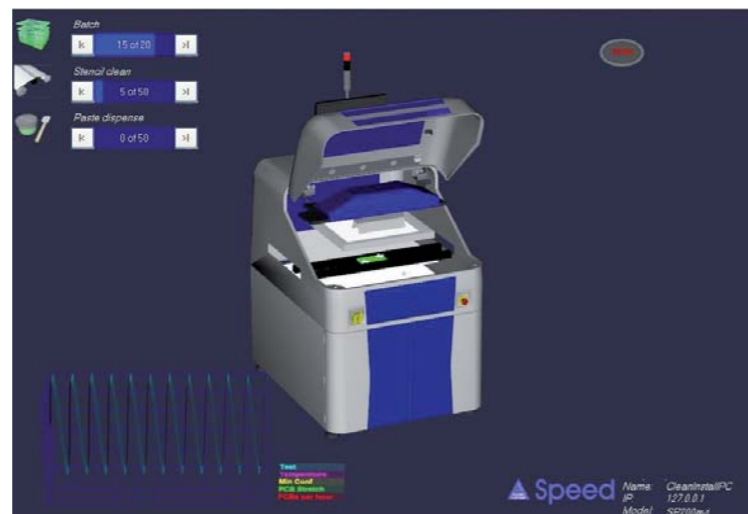

The combination of design quality and high component specification such as Precision Ground Ball-screws and 1 micron resolution Linear Encoders, which are fitted to all machine axes, guarantees maximum performance and an unrivaled level of reliability with the lowest cost of ownership.



Automatic rail width adjust is standard to aid quick changeovers in a high mix manufacturing environment. Stencil loading is automatic and the system does not require adaptors for varying sizes of stencil frames.

The PCB transport system includes a fully programmable board stop and employs pneumatically controlled foil PCB clamping. The system is SMEMA compatible to ease integration with fully automated SMT production lines.

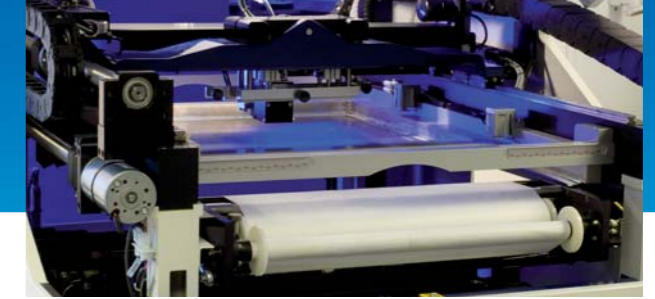

The automatic stencil loading facility enables the operator to easily switch between stencil frames at the touch of a button, thereby promoting fast changeovers and low cost of ownership.

The Vacuum Under Stencil Cleaner comes as standard, is fully programmable and features wet/dry operation with vacuum assist ensuring defect free printing.

### Standard features of the SP210 avi

- **1.2m<sup>2</sup> Footprint** – the most compact Printer in its class
- **High precision Ground Ball-screws** – fitted on all axes to provide the ultimate in accuracy and reliability
- **1 Micron resolution Linear Encoders** – on all axes for optimum positional accuracy
- **Twin Roving Cameras** – highly accurate and robust Vision Platform
- **Precision Mono-fabrication** – precision engineered base structure
- **Distributed Control Network** – localised axis control reducing cables and increasing reliability
- **3Dc User interface** – the simplest and intuitive of User Interfaces
- **Paste on Stencil inspection** – providing feedback & set up of paste replenishment, a unique feature within the SP210avi
- **Fully automatic Conveyor Adjustment** – provides flexibility to manage a variety of PCB sizes
- **Programmable Vacuum Stencil Cleaner** – highly efficient wet and dry stencil cleaning system
- **Closed Loop Squeegee control** – provides full control of the Print process
- **Auto Stencil Load and eject** – improved speed and ease of product changeover
- **Fully adjustable internal Stencil frame** – removes the need for external Adaptors