

# COMPACT SERIES

Small

Robust

Value for Money



## The Smallest and Most Robust Sensing Head



Optris introduces new benchmarks within the area of industrial infrared thermometers regarding the size and robustness of the sensing heads. The miniaturized sensing heads are especially developed for the use in **small and cramped surroundings** and are perfect for applications with limited space, such as midgest instruments and engine constructions. The very **advantageous cost-performance-ratio** supports the integration within OEM solutions and simultaneous use of the measurement devices at **multiple infrared measuring facilities**.

The compact series devices offer inimitable advantages for the installation in applications with **high ambient temperatures**, such as within the plastic or paper industry. The robust and ambitious design allows the sensing heads to be used for temperatures up to 250°C without additionally cooling. This advantage help to reduce the costs for mechanical installations.

## The Different Device Designs

The first design of the compact series is the **single-piece sensing head**. The lens and electronic are build into a compact housing.



Secondly, Optris developed the two-wire devices with the **electronic integrated within the cable**. The robustness of the sensing heads can therefore be increased. The heat development of the two-wire electronic does not influences the thermal stability of the sensing head.



The third alternative is a two-piece device with a **sensing head and a separate electronic box**. The box offers the possibility to choose between different interfaces (see page 26f), additionally to the simple device configuration and a temperature display.



## Proven for Versatile Applications



The compact series covers many applications within the infrared temperature measurement technology. An important, overall segment of the applications is the **OEM market**, especially within the **engine and plant construction**. Operation examples are:



### Non-metal surfaces (LT)

- Plastic plates at cupping machines
- Laminating of decor and chip tray
- Drying processes within food industry
- Tarmac measurement for roadworks
- Pasteboard and paper drying within offset printer



### Special applications (P7)

- Plastic foil for blow moulding



### Glass surfaces (G5)

- Conversion of flat glass



### Metal surfaces (3M; 2M; 1M)

- **3M**: Measurement through plastic for welding onto carrier material
- **2M**: Melt measurement within melting plants (medical technology)
- **1M**: Shrinking processes

Wide Temperature Range



Depending on the wavelength and the type of device, different temperature ranges can be used. The following areas between **-50°C and 1800°C** are covered by the compact series:

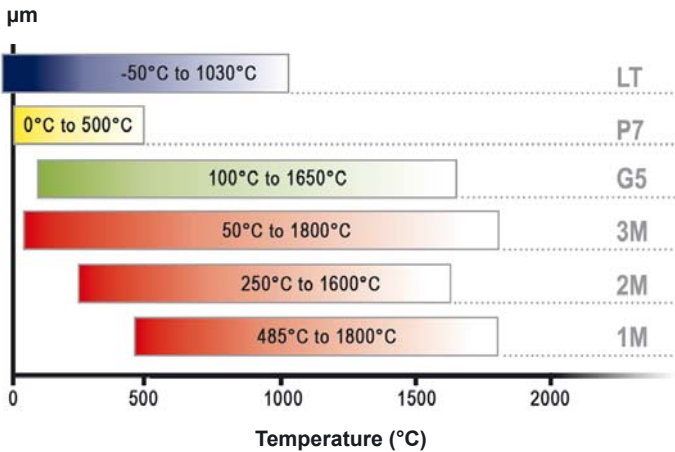

Temperature range of the compact series over the wavelength

Small Spot Sizes within Close and Mean Distances



The lenses of the compact series devices are especially developed for measurements in close and mean distances. The **standard lens** (SF, standard focus) can easily be changed into a **close lens** (CF, close focus) via the ancillary lens.

Example:  
0.6 mm @ 10 mm



Close lens (CF, close focus): Measurement of smallest measurement objects close to the sensor.

Example:  
7 mm @ 1.1 m



Standard lens (SF, standard focus): Measurement of smallest measurement objects in mean distances.

Suitable for Fast Processes



Different measurement velocities (response time) are available to you, depending on the measurement device and the kind of detector. The fastest long wavelength device is the optris CTfast with **6 ms** reaction time. Within the short wave area, difference in temperatures can precisely be measured within **1 ms**.

When Robustness Matters



The sensing heads of the compact series are developed for the installation in areas with high ambient temperatures.

All sensing heads are suitable for temperatures up to 75°C. Some sensing heads consist of an extreme **temperature resistance of up to 250°C**. Therefore, they support time and cost savings, as an additional cooling is not necessary.

If the device will be used in dusty and rough surroundings, an **air purge collar** (standard or laminar) can be combined with the sensing head.

The laminar air purge collar suits at small measurement distances, as it avoids the cooling down of the object due to a sideway air outled.

Additional **massive housings** are available for the M12x1 sensing heads in either brass, anodized aluminium or stainless steel. A protective conduit can be mounted to the housing for reflection protection.



The optris CThot; the sensing head with housing has a temperature resistance up to 250°C without additional cooling.

## The Fitting Interface for Your Measurement Task



Analog and digital interfaces are available for data evaluation depending on the device.

**Additional information** regarding the interfaces can be found on **page 26f**.

## Software for Parameterization and Documentation

The software *optris Compact Connect* allows simple and fast parameterization of the measuring devices and offers documentation of the measurement datas.

**Additional information** regarding the software can be found on **page 24f**.

## Device Example: *optris CS LT* for a Simple Introduction into Multiple Installations

The *optris CS LT* is a small, compact measuring device with an innovative LED display. In general the advantages of the *optris CS LT* are:

### Intelligence of the LED display

- Unique targeting help for sensor adjustments through automatic search of maximum merit (LED: on / off)
- Self-diagnosis with five different display modes (LED: blinking)
- LED display with fulfilled alarm condition, e.g. additionally to the alarm output of the device (LED: on /off)
- Temperature code display (LED: blinking code)

### Security

- Integrated permanent self monitoring (watch dog)
- Status request via LED self diagnosis

### User friendly

- Parameter of emissivity and alarm level via the supply voltage, for single or multiple sensors
- Scalable analog signals
- Drip device via open collector output (visual or acoustic alarm, switch)



*optris CS LT: compact, single-piece sensor for multiple installations*

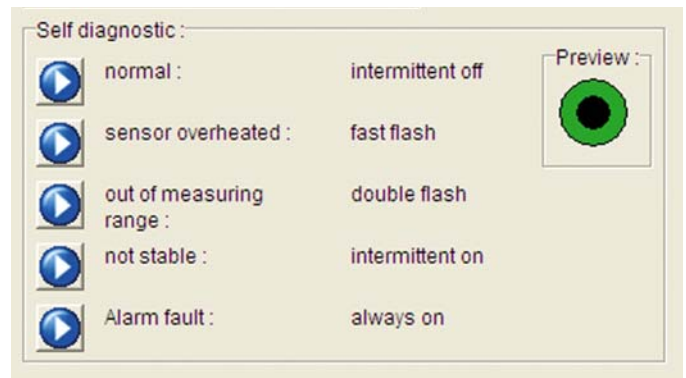

*Explanation of self diagnosis status of the software:*

- 1.) Normal: Device is working normal
- 2.) Sensor overheated: Ambient temperature above 80°C
- 3.) Out of measuring range: Object smaller -40°C or greater 1030°C
- 4.) Not stable: Device thermally instable, e.g. during switch-off or increasing of applied voltage
- 5.) Alarm fault: Open collector switched off, e.g. during fitting of too high voltage

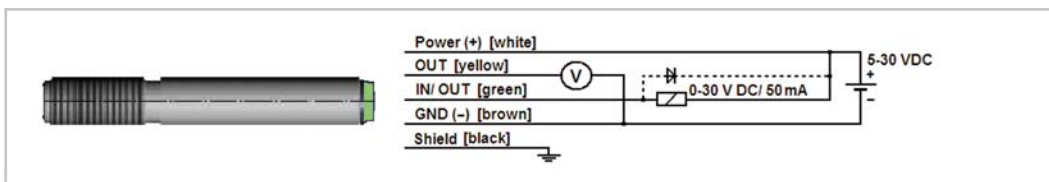

*Device within analog operation with mV signal and alarm output (Open-Collector) at in- / out-pin*



*Device with simultaneous analog & digital operation with complete parameterization possibility via software*

Device Example: Mobile Measurement System for Material Analysis

The optris CTtrans system combines the optris CT LT infrared thermometer with an infrared emitter. It assigns the material parameter transmission for different previous materials (e.g. foils). The definition of the reflectivity is also possible. Both **parameters (transmission, reflectivity)** can be passed on manually or automatically to an additional infrared thermometer or to the **PLC**. This is in use to define the temperature for changing material properties during manufacturing processes, for example.

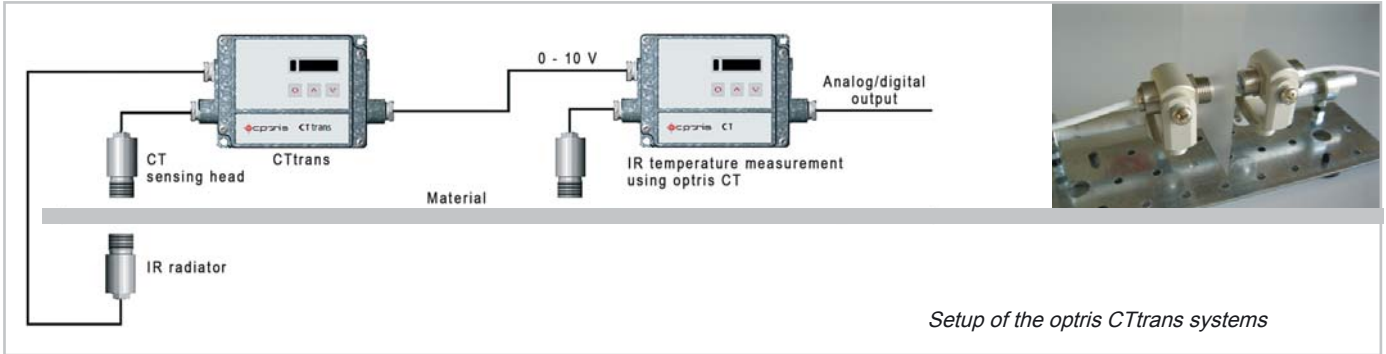

Device Example: optris CT LT for the Use in Explosive Areas

The sensing heads of the optris CT LT devices belong to the category simple electronic current assets according to EN 50014. As no special certificate for intrinsic safety is necessary, the devices can be used as **passive elements** within **explosive areas**.

Indemnification for the intrinsic safety is secured through the boundary of the energy supplied to the sensing head with two Zener double batteries of the type 9002/22-032-300-111 (R. STAHL AG). Therefore they are allowed to be used in zone 1 (PTB 01 ATEX 2053/ E II (1/2) GD [EEx ia/ib] IIC/IIB).

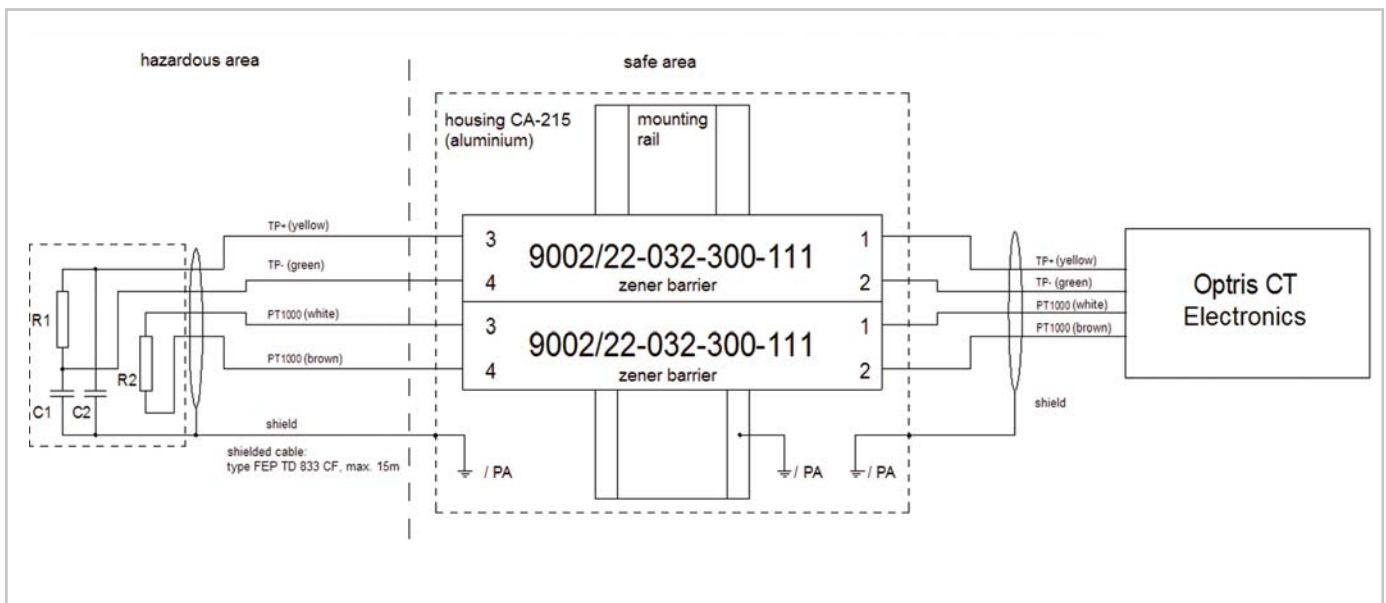
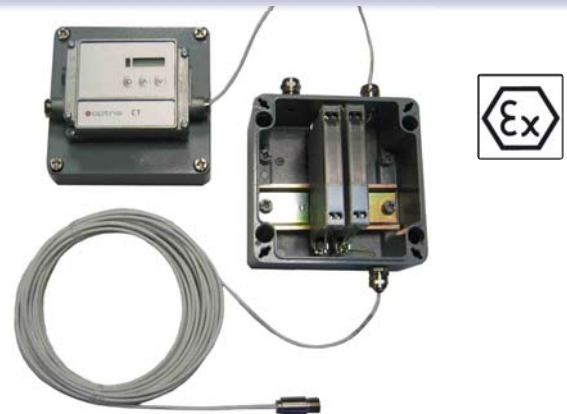

*Setup of the optris CT LT devices for the use in Ex protected areas.*

## Mechanical Accessories



Mounting angle, adjustable in one axis (M12x1-sensing head, massive housing, 2-hole for M12x1)



Mounting bolt for M12x1 sensing head, adjustable in one axis



Mounting fork for M12x1 sensing head, adjustable in two axes



Massive housing, available in brass, anodized aluminium or stainless steel



Rectangular mirror for measurement with 90° to sensor axis



Air purge collar, for M12x1 sensing head



Air purge collar, for massive housing



Air purge collar laminar, for M12x1 sensing head



Massive housing with air purge collar, for M12x1 sensing head



Reflection protection pipe and pipe adapter, for M12x1 sensing head

## Mechanical Accessories

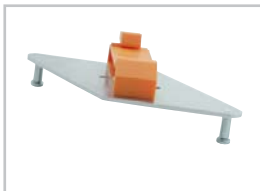

Rail mount adapter, for CT electronic box



Closed device cover, for CT electronic box



CF ancillary lens or protection window, for M12x1 sensing head



CF ancillary lens or protection window, for air purge collar (laminar) or massive housing



OEM laser sight support, supply via CT electronic box or batteries

## Ancillary Lens / Protection Window / Sight Support

## Examples of Possible Combination of Accessory Parts of the Compact Series



Air purge collar, laminar

+



Mounting fork

=



Device adjustable in two axes



Mounting angle (2-hole)

+



OEM laser sight support

=



Sensing head with laser sight support



Mounting angle for M12x1 sensing head

+



Mounting bolt

=



Device adjustable in two axes



Massive housing, stainless steel

+



Air purge collar, stainless steel

=



Massive housing with air purge collar